

SKG-IKOB-KE 571
2004-01-01



bezoekadres
Poppenbouwing 56
4191 NZ Geldermalsen

postadres
Postbus 202
4190 CE Geldermalsen

T +31 (0)88 244 01 00
F +31 (0)88 244 01 01
E info@skgikob.nl
I www.skgikob.nl

SKG-IKOB – KWALITEITSEISEN 571

FOR ISSUING OF SKG-IKOB PRODUCTCERTIFICATES FOR IMPACT- AND/OR VANDALISM RESISTANT LIGHTING FIXTURES

Established by CvD Safe and Burglary Resistant Products dd. 09 October 2003

GENERAL INFORMATION

These SKG-IKOB-KE 571 Impact resistant and vandalism resistant lighting fixtures (demands) have been established by a supervisory committee and the College of Experts (CvD), in which the following parties in the field of Safety and Burglar resistant products (V&I) are represented:

Supervisory committee:

- Institute Police Mark Save Housing (PKVW)
- Manufacturers
- KEMA

College of Experts

- VHS (manufacturers of Building Hardware)
- ABHS (General organisation for Building Hardware)
- Glas Branche Organisatie (GBO)
- Centre for Criminality Prevention and Security (CCV)
- SKH (Foundation for Approval of Wood construction)
- National Police Institute (NPI)
- Aegon Insurance Co.
- NL-ingenieurs
- NSSG (Netherlands Key- and Lock specialists Guild)

The college also monitors the certification process and amends this guideline if necessary. Where this guideline refers to "College of Experts", the college mentioned above is meant.

This guideline will be followed by SKG-IKOB together with the Rules and Regulations used by SKG-IKOB. These Rules specify the working method to be followed when carrying out tests for the award of the product certificate, as well as the working method for external inspections. The V&I College of Experts formed the support committee for drawing up this document.

SKG-IKOB is approved, in accordance with NEN-EN 45011 (C003) and NEN-EN-ISO/IEC 17021 (C063), by the Dutch Accreditation Council (RvA) for the following certification systems:

- Attestation
- Product certification
- Process certification
- ISO 9001 certification
- VCA certification

The laboratory of SKG-IKOB is accredited by the Dutch Accreditation Council (RvA) for various activities in the area of façade elements, lock- and hardware products and glass, according to NEN-EN-ISO/IEC 17025 (L406)

© 2004 SKG-IKOB

All rights reserved. No part of this publication may be reproduced, stored in an automated database or made public, in any form or in any way whatsoever, whether electronically, mechanically, by photocopying, recording or otherwise, without written permission in advance from the publisher. This without prejudice to the fact that all rights are owned by SKG-IKOB. The use of this guideline by third parties, for any purpose whatsoever, is solely permitted after a written agreement has been signed with SKG-IKOB defining the rights of use.

Legal declaration

This guideline is declared legally binding by the SKG-IKOB Executive Board with effect from 29 October 2003.



SKG-IKOB
Poppenbouwing 56
4191 NZ Geldermalsen
Postbus 202
4190 CE Geldermalsen
The Netherlands
Telephone +31 (0)88-2440100
Telefax +31 (0)88-2440101
Internet www.skjikob.nl

INDEX	PAGE
1. INTRODUCTION	4
1.1 Subject	4
1.2 Area of application	4
1.3 Date of commencement and period of validity	4
2. PROCEDURE FOR OBTAINING A SKG-IKOB QUALITY CERTIFICATE	5
2.1 Certification investigation (for new certificate holders only)	5
2.1.1 Primary product approval as part of the Certification Investigation	5
2.1.2 Assessing the applicant's quality system	5
2.1.3 Entering into a certification agreement	5
2.1.4 Issuing of the SKG-IKOB quality certificate	5
2.1.5 External quality care	5
2.2 Handling of applications for quality certificates under an existing certification agreement	6
2.2.1 Application	6
2.2.2 Primary product approval as part of the application for new quality certificates	6
2.2.3 Issuing of the SKG-IKOB product certificate	6
3. REQUIREMENTS FOR IMPACT RESISTANT AND/OR VANDALISM RESISTANT LIGHTING FIXTURES	7
3.1 General performance requirements and requirements corresponding to the category "impact resistant"	7
3.1.1 Electrical safety	7
3.1.2 Impact resistance	7
3.2 Additional performance requirements corresponding to the class "vandalism resistant"	7
3.2.1 Fire resistance - flame extinguishing properties	7
3.2.2 Graffiti resistance	7
3.2.3 Resistance to striking implements – Impact-resistant test with ball	7
3.2.4 Resistance to striking implements – Impact-resistant test with hammer	8
3.2.5 Resistance to manual assault	8
3.3 Requirements for the fitting instructions	8
4. CLASSIFICATION AND DESIGNATION	9
5. TESTING METHODS	10
5.1 Fire resistance test	10
5.2 Graffiti resistance test	10
5.3 Impact-resistant test with ball	10
5.4 Impact-resistant test with hammer	11
5.5 Manual test	11
6. REQUIREMENTS FOR THE QUALITY SYSTEM OF SKG-IKOB-CERTIFICATE HOLDER	13
6.1 Product and production control/ requirements to be set for the quality system / production manual	13
6.2 Measuring and testing equipment	13
6.3 Complaints registration	13
6.4 Spare parts and graffiti removers	13
7. VERIFICATION BY THE CERTIFICATION INSTITUTE	14
7.1 Verification for obtaining the SKG-IKOB product certificate (Primary approval or Type approval)	14
7.2 Verification of maintenance of the SKG-IKOB Quality certificate	14
7.3 Verification aspects and frequency of verification	14
7.4 Verification of the operation of Internal Quality Control	14
7.5 Verification of the use of identification marks	14
8. LIST OF DOCUMENTS CITED	15

1. INTRODUCTION

1.1 Subject

The requirements included in these quality requirements will be used by SKG-IKOB in the handling of applications for or maintaining a certificate for impact- and vandalism resistant lighting fixtures, hereafter referred to as lighting fixtures. The quality certificate to be issued shall be known as the "SKG-IKOB Quality certificate". A SKG-IKOB quality certificate may be issued only if the applicant has entered into a certification agreement with the certification institution.

An SKG-IKOB Quality certificate may be issued only if the applicant (apart from possibly being responsible for the design) is also responsible for the (regular) production of lighting fixtures, or responsible for the delivery of the lighting fixture.

An SKG-IKOB Quality certificate may be issued only if the lighting fixture meets the requirements of electrical safety

EN-60598-1 and EN-60598-2-1. To proof this, the armature must be provided with CE-marking.

In addition to the requirements set down in these SKG-IKOB-KE, the certification institutions will set additional requirements in the sense of general procedural requirements for certification, as established in the regulations of the institution concerned.

1.2 Area of application

A lighting fixture in accordance with the guidelines in these SKG-IKOB-KE, satisfies the requirements for impact resistance and/or vandalism resistance, and may contribute to the social security if used correctly.

1.3 Date of commencement and period of validity.

These SKG-IKOB-KE will take effect immediately on the date of publication.

Quality certificates in accordance with these SKG-IKOB-KE shall be valid for a period of 5 years as long as periodical verification by the certification institution shows that specifications have not been changed in such a way as to necessitate an application for a new quality certificate and as long as the certificate holder has satisfied all his or her obligations arising from the certification agreement.

Following the aforementioned period of 5 years, the applicant must re-submit the application on time or no less than 3 months before the expiration date stated on the quality certificate.

These SKG-IKOB-KE may be cited as: **SKG-IKOB-KE 571 for impact- and/or vandalism resistant lighting fixtures.**

2. PROCEDURE FOR OBTAINING AN SKG-IKOB QUALITY CERTIFICATE

2.1 Certification investigation (for new certificate holders only)

By submitting a written application, the applicant indicates that he/she wishes to enter into a certification agreement with the certification institution and therefore wishes to qualify for a quality certificate for one or more of his/her products. The applicant for the quality certificate indicates to which by the applicant manufactured lighting fixtures he wishes to have statements included in the quality certificate, in order to demonstrate by means of the certification that his lighting fixtures continue to be in accordance with the requirements to be set for them. As an indication that the products satisfy the impact resistant and/or vandalism resistant requirements to be set for them, the certification agreement shall entitle and oblige him/her to affix the relevant identifying marks as stipulated in the certificate. He/she will provide the necessary information for drawing up the "technical specification".

2.1.1. Primary product approval as part of the Certification Investigation

The certification institution will investigate whether the classification included in the quality certificate corresponds to the relevant requirements according to section 3 of these SKG-IKOB-KE.

This will take place on the basis of laboratory tests including, if necessary, a number of "manual tests". All of this as stipulated in Section 3.

The tests will establish whether the requirements set have been satisfied.

When the electrical safety of the lighting fixtures is not guaranteed through a certification agreement with a licensed certification organisation, SKG-IKOB will submit the product for inspection to an approved laboratory.

Remark: In principle, SKG-IKOB will submit products for review, according to the requirements of EN 60598-1 and EN 60591-2-1, to KEMA in Arnhem.

2.1.2 Assessing the applicant's quality system

The certification institution will establish whether the applicant's quality system is in accordance with the stipulations of section 6 or whether the candidate certificate holder is prepared and able to set up and implement such a system within a reasonable time after entering into the certification agreement. All of this is at the discretion of the certification institution.

The quality certificates can be issued (see 2.1.4) only after it has been demonstrated that the applicant's quality system satisfies the stipulations of section 6.

2.1.3 Entering into a certification agreement

When primary product approval (2.1.1) and assessment of the applicant's quality system (2.1.2) have been successfully completed, the applicant will be offered a certification agreement in accordance with the general conditions for Product Certification of the certification institution.

In this, the applicant shall subject him/herself to the conditions of Product Certification and therefore to the inspection regime included in these and the sanction provision.

Moreover, the certificate holder shall undertake to provide his/her products with the SKG-IKOB identifying mark and an identification designation in the prescribed manner (indelible), according to section 4.

2.1.4 Issuing of the SKG-IKOB product certificate

The quality certificate will conform to the relevant model in appendix 1 and will be issued in accordance with the SKG-IKOB rules for product certification and the certification agreement. The quality certificate will be issued for the products for which primary product approval has been successfully concluded.

2.1.5 External quality care

After entering into a certification agreement, the certification institution will carry out verification as described in section 6.

2.2 Handling of applications for quality certificates under an existing certification agreement

2.2.1 Application

The certificate holder will let it be known that he/she wishes to be considered for a new quality certificate for one of his/her products based on these SKG-IKOB-KE.

2.2.2 Primary product approval as part of the application for new quality certificates

The certification institution will investigate whether the classification to be included in the quality certificate corresponds to the relevant requirements according to section 3 of these SKG-IKOB-KE.

This will take place on the basis of laboratory tests as well as by the certification institution establishing that the product can withstand a manual test in a relevant practical situation. All of this as stipulated in Section 3.

2.2.3 Issuing of the SKG-IKOB product certificate

The quality certificate will conform to the relevant model in appendix I and will be issued in accordance with the SKG-IKOB rules for product certification.

3. REQUIREMENTS FOR IMPACT RESISTANT AND/OR VANDALISM RESISTANT LIGHTING FIXTURES

3.1 General performance requirements and requirements corresponding to the class "impact resistant"

3.1.1 Electrical safety

Lighting fixtures must satisfy the requirements of electrical safety pertaining to class IP 55 according to EN 60598-1 and EN 60598-2-1.

3.1.2 Impact resistance

Lighting fixtures in the class "impact resistant" must withstand a falling ball test as described in chapter 5.3 for the class "impact resistant".

For this test, the base material on which the product should be fitted and the fastening materials that should be used are also specified.

COMMENT: Base materials may be: Concrete (min. B25), Masonry, Wood etc.

If the applicant wishes to include more than one base material in the mounting instructions, the test as described in chapter 5.3 must be carried out for each base material.

Withstand means: product is visually (examined by daylight at a distance of 3 metres) and functionally undamaged, is still firmly attached and still satisfies IP 55.

3.2 Additional product requirements corresponding to the class "vandalism resistant"

Besides the requirements stated in sections 3.1.1 and 3.1.2, lighting fixtures in the class "vandalism resistant" must also satisfy the additional performance requirements mentioned below.

3.2.1 Fire resistance – flame extinguishing properties

Lighting fixtures must withstand a test as described in chapter 5.1

Withstand means: once the flame is removed, the fire must be extinguished within 5 seconds.

After the test, the product must still apparently satisfy the Dust exclusion and Watertightness classification IP55 in accordance with EN 60598-1.

If there are doubts about this, then a test in accordance with EN 60598-1 should actually be carried out.

It is possible, though, that the product may be irreparably damaged by the assault.

3.2.2 Graffiti resistance

Lighting fixtures must withstand a test as described in Chapter 5.2.

Graffiti resistant means: after the test, the graffiti may not be undesirably present (in other words: either by daylight with the light switched off or in the dark with the light switched on, it must not be visible from a distance of 3 metres) and the light transmittance, assessed without aids, may not have deteriorated noticeably.

COMMENT: After removal of the graffiti, it must NOT be necessary for the products to then be treated with some product or another.

Instructions can indicate, though, that the products must be treated according to a plan (with an interval of 5 years or longer).

The provider can choose to satisfy the requirement for graffiti resistance by replacing damaged components with components for which there is an arrangement for keeping these in stock.

Comment: this must be mentioned and offered at the tendering stage. See chapter 6.4.

3.2.3 Resistance to Striking implements – Impact-resistance test with ball

Lighting fixtures in the class "vandalism resistant" must withstand an impact-resistance test using a falling ball as described in chapter 5.3 for the class "vandalism resistant".

For this test, the base material on which the product should be fitted and the fastening materials that should be used are also specified.

If the applicant wishes to include more than one base material in the fitting instructions, the test as described in chapter 5.3 must be carried out for each base material.

Comment: Base materials may be: Concrete (min. B25), Masonry, Wood etc.

Withstand means: the product is still attached to the base material and still apparently satisfies the Dust exclusion and Watertightness classification IP55 in accordance with EN 60598-1 after the test.

If there are doubts about this, then a test in accordance with EN 60598-1 should actually be carried out.

3.2.4 Resistance to Striking implements – Impact-resistance test with hammer

Lighting fixtures in the class "vandalism resistant" must withstand an impact-resistance test using a falling hammer as described in chapter 5.4.

Withstand means: after the test, the product must still seem on the basis of visual inspection to satisfy the Dust exclusion and Watertightness classification IP55 in accordance with EN 60598-1.

If there are doubts about this, then a test in accordance with EN 60598-1 should actually be carried out.

If there is damage, then this damage is relatively easy to repair with components for which there is an arrangement for keeping these in stock.

Comment: this must be mentioned and offered at the tendering stage. See chapter 6.4.

3.2.5 Resistance to manual assault

Lighting fixtures in the class "vandalism resistant" must withstand a manual assault as described in chapter 5.5
Withstand means: product still functions and is still attached to the base material.

The product may actually be damaged.

If there is damage, then this damage is relatively easy to repair with components for which there is an arrangement for keeping these in stock.

Comment: this must be mentioned and offered at the tendering stage. See chapter 6.4.

3.3 Requirements for the mounting instructions

The mounting instructions include:

- Instructions necessary for correct electrical connection;
- The base material(s) for which the product has been found suitable;
- The fastening materials for all base materials for which the product is considered suitable must be provided with the product;
Alternative: a precise description of the fastening materials to be used;
- The drill diameter that must be used per base material;
- Information about where spare parts can be obtained;
- Cleaning instructions, including which cleaning materials can be used;
- Recommendations for the removal of graffiti including which materials should be used for which type of graffiti and the advice that cleaning work must be started within 24 hours of the graffiti being applied;
- Alternative: recommendations for the removal of graffiti including which components are available from stock for replacing components damaged by graffiti.

4. CLASSIFICATION AND DESIGNATION

Lighting fixtures that satisfy the class "Impact resistant" according to section 3 will be indelibly marked (either on the lighting fixture itself or on the CE-sticker) with the SKG mark using one ✓.

Lighting fixtures that satisfy the class "Vandalism resistant" according to section 3 will be indelibly marked (either on the lighting fixture itself or on the CE-sticker) with the SKG mark using two ✓✓.

As featured below.



5. TESTING METHODS

5.1 Fire resistance test

Attempts will be made to set fire to the product at a maximum of three places to be decided by the certification institution.

Burner: disposable cigarette lighter with adjustable flame height. Flame height approx. 4 cm.

Time: 1 minute per location.

5.2 Graffiti resistance test

Product is degreased using water and dishwashing detergent. After drying, the following products are applied at the locations to be decided by the CI/TI:

Edding Marker (or equivalent), black

Acrylic spray paint "silver".

Acrylic spray paint, blue.

Alkyd spray paint

"Undercoating" such as Tectyl (or equivalent).

To do this, a stencil with an opening of approx. 2500 mm² is placed on the product. In the middle of the opening, a paper sticker with a surface area of approx. 100 mm² is applied. The maximum spraying or application time is long enough to ensure that when spraying or application is done uniformly, the sticker is no longer visible.

After a drying time of 7 days, attempts will be made for a maximum of 1 minute to remove the paint or ink using the following items in succession:

A. Hot or cold water.

B. Generally available cleaning materials: For example: washing or dishwashing detergents, paraffin, thinner etc. This will be done in accordance with the specifications of the manufacturer of the lighting fixtures.

C. Special graffiti removers in accordance with the specifications of the manufacturer.

5.3 Impact-resistance test with ball

A steel ball is dropped on a maximum of three locations on a product fitted in accordance with the fitting instructions (but at different angles).

Location 1: On the middle of the product in the direction perpendicular to the wall on which the product is fitted.

Location 2: On the side of the product in a direction parallel to the wall on which the product is fitted.

Location 3: If the test institution suspects from the nature of the construction of the product that the product has clearly vulnerable locations that will not be revealed by a test on locations 1 and 2, a third test may be requested at a location to be decided by the test institution

The product is fitted on a base material to be specified by the applicant.

Ball specification: Diameter 100 mm, Mass 4.11 kg.

	Class:	Impact resistant	Vandalism resistant
Ball falling height in mm		480	1600
Ball impact in J.		20	67

5.4 Impact-resistance test with hammer

This test is solely intended to test the actual lighting fixture. The quality of the fastening is tested by means of the falling ball test.

See the diagram for the test configuration.

The test must be carried out on a maximum of two locations, to be decided by the test institution, on the unattached product.

Height of fall: 850 mm (+/- 10 mm)

Mass of hammer incl. fastening material to arm: 4.85 ± 0.05 kg

Mass of arm:± kg, centre of gravity 500 ± 20 mm from hinge point.

The test item is positioned in such a way that the arm of the hammer is horizontal at the first contact.

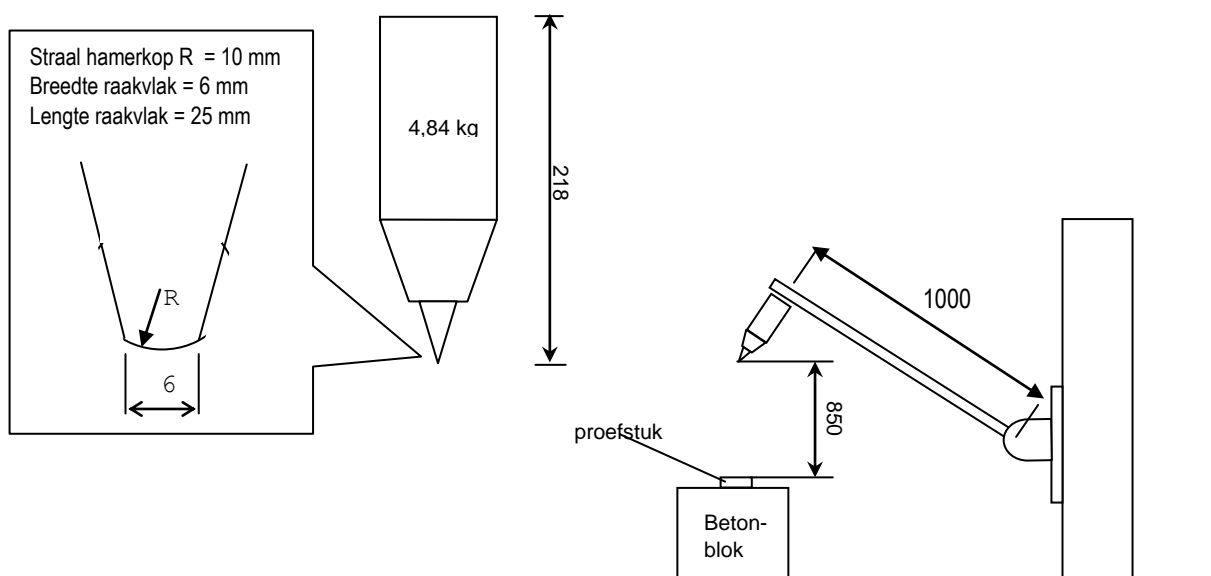

5.5 Manual test

The product is fastened to the base material specified and using materials as specified by the applicant. The product is fitted at a height above the working surface that depends on the height of the inspector (to eliminate the influence of height differences between inspectors).

Distance between working surface and centre of lighting fixture is the height of the inspector + 400mm ± 30 mm.

If the lighting fixture can be fitted in more than one position (e.g. horizontal or vertical), the test institution will choose the most vulnerable position.

The net assault time is defined as the time during which the inspector actually attempts to dismantle the fixture or tear it from the wall. This net assault time is 60 sec. and must be expended within a total test time of 5 minutes.

Only 1 assault tool at a time may be used.

The test time commences when a tool first makes contact.

The test institution must be able to collect preliminary information without restrictions about the vulnerable aspects of the product. If desired, the test institution may decide to carry out a preliminary test before the actual test.

Toolset

Assault tools:

- | | |
|---------------------|---|
| 1 Screwdriver | total length approx. 260 mm, blade width 10 mm. |
| 1 Pipe wrench | total length approx. 240 mm |
| 1 Box wrench | total length approx. 280 mm |
| 1 Adjustable wrench | total length approx. 250 mm |

Manipulating tools:

- 1 set of small crosshead screwdrivers up to a max. diameter of 6 mm.
- 1 set of small slotted screwdrivers up to a max. diameter of 6 mm.
- 1 set of hexagonal keys up to 10 mm
- 1 pocket knife, max. blade length approx 100 mm.
- 1 set of double-ended spanners up to 15 mm.

Photo toolset:



6. REQUIREMENTS FOR THE QUALITY SYSTEM OF SKG-IKOB CERTIFICATE HOLDERS

6.1 Product and production control/ requirements to be set for the quality system / production manual

The SKG-IKOB quality certificate holder must have a fully functional quality system that is demonstrably in accordance with what has been established in a production manual for this purpose.

Recommendation

The certificate holder's quality system should preferably conform to the requirements in accordance with ISO 9001 taking into account that the requirements for products stated in these SKG-IKOB-KE, are up to standard, in order to guarantee that the product supplied by the certificate holder constantly satisfies the requirements.

Requirements to be set for the production manual:

In order to avoid differences of opinion and interpretation, the production manual should fully, clearly and unambiguously contain all the relevant data for the proper production or supply of the anti-theft products. This must include the following (where relevant):

- a. the presence in the organisation structure of an officer charged with the management of the quality system.
- b. the presence of up-to-date documentation on the certified product and also (if relevant) on the semi-manufactured products incorporated in it, of which it must be possible to show that their suitability for processing into anti-theft products is in accordance with the stipulations in these SKG-IKOB-KE.
- c. the presence and functionalism of a system of internal quality control set down in writing.
This includes work instructions, etc., for the registration of data such as:
 - * intake check of purchased raw materials, semi-manufactured products and end products;
 - * production process control (also in the case of sub-outsourcing under contract);
 - * end product control
- d. measuring and research facilities, including their calibration (see 5.3);
- e. settlement of faulty products;
- f. the effectiveness of corrective measures in the case of identified imperfections and faults.
- g. a complaints procedure including registration and settlement (see 5.4);
- h. a procedure for the identification of products (article numbers, identifying marks, logos, etc.).

6.2 Measuring and testing equipment

In order to carry out the required registrations, the certificate holder must have the (calibrated) equipment necessary for adequate quality control, as well as measuring equipment with the degree of accuracy needed for the desired result.

6.3 Complaints registration

The holder of a quality certificate or a certificate must keep a complaints book in which he/she registers all complaints referring to products to which the quality certificate applies.

For each complaint, the complaints book must indicate in what way the complaint was analysed in what way the complaint was settled.

6.4 Spare parts and graffiti removers

The holder of a product certificate is required to set up a system making it easily possible to deliver at a later date components that can be damaged and graffiti removers that have proved necessary during the tests described in these quality requirements.

The holder of a product certificate is required to clearly state the unit prices of these spare parts and graffiti removers when a tender is made to the end user.

7. VERIFICATION BY THE CERTIFICATION INSTITUTION

7.1 Verification for obtaining the SKG-IKOB product certificate (Primary approval or Type approval)

Primary product approval consists of tests to establish that products satisfy the requirements of section 3. For carrying out the tests, products submitted for certification must be taken randomly from continuous production. If the certification institution deems it advisable, all laboratory tests will be carried out 3 times and the results set down in a report. The results of primary approval will be considered positive and will lead to the issuing of a quality certificate when the padlock appears to satisfy the requirements of section 3 in all of the tests.

NB: If no products are available from continuous production (e.g. in the case of prototypes) the results of primary approval can lead only to the conditional issuing of a quality certificate. Such products can only be marketed with the stars sign after the sample from continuous production and the prototype example have been shown to be identical, possibly following further primary approval.

7.2 Verification for maintenance of the SKG-IKOB product certificate

The certification institution will carry out periodical and unannounced verification as to whether the products satisfy the technical specification and whether the holder's quality system satisfies the requirements. Supplying products under the quality certificate that do not satisfy the specifications of the quality certificate in accordance with the stipulations of these SKG-IKOB-KE may, in the first instance (if no corrective measures are taken that are deemed adequate by the certification institution) lead to the withdrawal of the right to use the quality certificate for the product concerned and, in the case of a persistent lack of quality, will lead to the termination of the certification agreement.

In the case of complaints, the certificate holder must demonstrate to the satisfaction of the complainant that the product supplied by him/her is at least equal in value to what he/she is offering and provides a performance corresponding to that stated in the quality certificate, unless other agreements have been clearly made in the agreement. The certification institution is authorised to establish the justifiability of the complaint by means of verification (possibly in the factory) and to demand corrective measures.

7.3 Verification aspects and frequency of verification

The way in which the verification of the product is carried out, as well as the frequency of visits, will be established by the Board of Experts in accordance with the advice that the board provides to the certification institutions.

Rmk: In principle, no manual tests are carried out in the case of product verification for maintaining the quality certificate.

Rmk Starting from the date of commencement of these SKG-IKOB-KE, the verification frequency has been established as follows: for each certificate holder a minimum of 3 products a year; for each certificate m 1 product per year. The lighting fixtures needed for the verification check will be randomly acquired from market sources, in a manner determined by the certification institute.

7.4 Verification of the operation of Internal Quality Control

Once a year, the Internal Quality Control of each certificate holder will be verified and evaluated.

Rmk: The certification institution may decide to omit this verification in the case of companies that are ISO-9001 certified if, in the judgment of the certification institution, it has been sufficiently shown that quality control of the product and of production products certified in accordance with these assessment guidelines are part of ISO quality system and when it has been established that the institution responsible for ISO certification can make an informed judgment on this.

7.5 Verification of the use of identification marks

The certification institution will verify whether the identification marks and the method of marking have been correctly applied, as well as whether the product can be traced back to a quality certificate by means of this identification.

8. LIST OF DOCUMENTS CITED

EN-ISO 9001:2000	/ Quality Management Systems – Requirements
EN-ISO/IEC 17025:2000	/ General requirements for the competence of testing and calibration laboratories.
EN 45011:1998	/ General criteria for certification bodies operating product certification.
EN 45012:1998	/ General criteria for certification bodies operating quality system certification.
EN 45014:1998	/ General criteria for suppliers' declarations of conformity
EN 60598-1	/ General criteria for lighting.
EN 60598-2-1	/ Additional criteria for general lighting.
NEN 5096	/ Burglary prevention - Requirements, classification and testing methods.

¹⁾ Note 1: The year of the last published addition or correction is noted after each document.